

# NordicTrack **E 11.7**

www.nordictrack.com

Model No. NTEL18913.0

Serial No. \_\_\_\_\_

Write the serial number in the space above for reference.

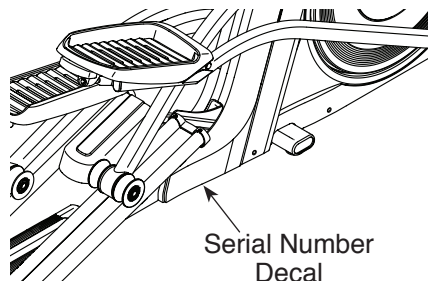

## ACTIVATE YOUR WARRANTY

To register your product and activate your warranty today, go to [www.nordictrackservice.com/registration](http://www.nordictrackservice.com/registration).

## CUSTOMER CARE

For service at any time, go to [www.nordictrackservice.com](http://www.nordictrackservice.com).

Or call 1-800-TO-BE-FIT  
(1-800-862-3348)  
Mon.–Fri. 6 a.m.–6 p.m. MT  
Sat. 8 a.m.–12 p.m. MT

Please do not contact the store.

## ⚠ CAUTION

Read all precautions and instructions in this manual before using this equipment. Keep this manual for future reference.

## USER'S MANUAL

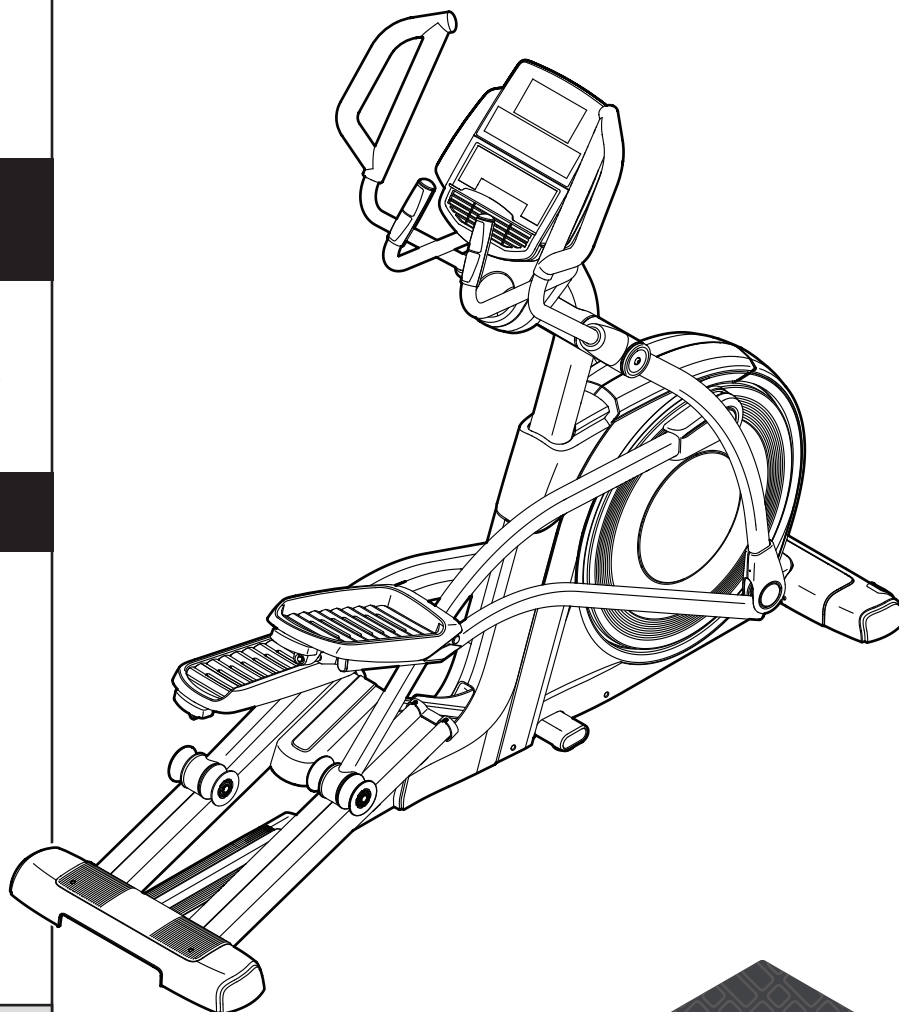

# TABLE OF CONTENTS

WARNING DECAL PLACEMENT .....	2
IMPORTANT PRECAUTIONS .....	3
BEFORE YOU BEGIN .....	6
PART IDENTIFICATION CHART .....	7
ASSEMBLY .....	8
THE CHEST HEART RATE MONITOR .....	12
HOW TO USE THE ELLIPTICAL .....	13
FCC INFORMATION .....	23
MAINTENANCE AND TROUBLESHOOTING .....	24
EXERCISE GUIDELINES .....	26
PART LIST .....	28
EXPLODED DRAWING .....	30
ORDERING REPLACEMENT PARTS .....	Back Cover
LIMITED WARRANTY .....	Back Cover

## WARNING DECAL PLACEMENT

This drawing shows the location(s) of the warning decal(s). **If a decal is missing or illegible, see the front cover of this manual and request a free replacement decal. Apply the decal in the location shown.** Note: The decal(s) may not be shown at actual size.

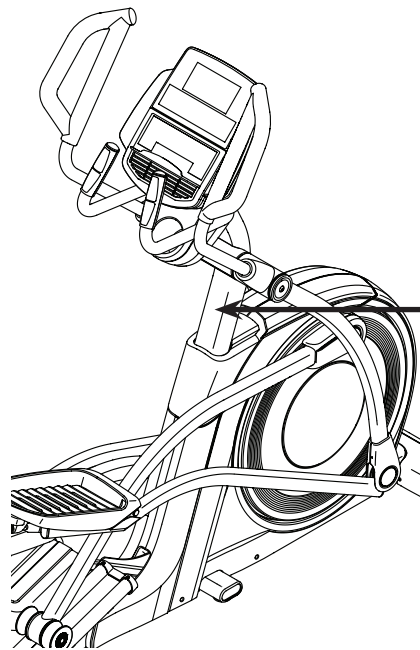

**⚠ WARNING**

- Misuse of this machine may result in serious injury.
- Read user's manual prior to use and follow all warnings and instructions.
- Do not allow children on or around machine.
- Pedals continue to spin when you stop pedaling.
- Spinning pedals can cause injury.
- Reduce pedal speed in a controlled manner.
- User weight must not exceed 350 lbs / 159 kgs.
- This product should always be used on a level surface.
- This product is not intended for therapeutic use.
- Replace label if damaged, illegible, or removed.

# IMPORTANT PRECAUTIONS

**⚠️ WARNING:** To reduce the risk of burns, fire, electric shock, or injury to persons, read all important precautions and instructions in this manual and all warnings on your elliptical before using your elliptical. ICON assumes no responsibility for personal injury or property damage sustained by or through the use of this product.

1. It is the responsibility of the owner to ensure that all users of the elliptical are adequately informed of all precautions.
2. Before beginning any exercise program, consult your physician. This is especially important for persons over age 35 or persons with pre-existing health problems.
3. Use the elliptical only as described in this manual.
4. The elliptical is intended for home use only. Do not use the elliptical in a commercial, rental, or institutional setting.
5. Keep the elliptical indoors, away from moisture and dust. Do not put the elliptical in a garage or covered patio, or near water.
6. Place the elliptical on a level surface, with at least 3 ft. (0.9 m) of clearance in the front and rear of the elliptical and 2 ft. (0.6 m) on each side. To protect the floor or carpet from damage, place a mat under the elliptical.
7. Inspect and properly tighten all parts regularly. Replace any worn parts immediately.
8. Keep children under age 12 and pets away from the elliptical at all times.
9. When connecting the power cord (see page 13), plug the power cord into a grounded circuit.
10. Do not modify the power cord or use an adapter to connect the power cord to an improper receptacle. Keep the power cord away from heated surfaces. Do not use an extension cord.
11. Do not operate the elliptical if the power cord or plug is damaged, or if the elliptical is not working properly.
12. **DANGER:** Always unplug the power cord and switch the power switch to the off position when the elliptical is not in use and before cleaning the elliptical. Servicing other than the procedures in this manual should be performed by an authorized service representative only.
13. The elliptical should not be used by persons weighing more than 350 lbs. (159 kg).
14. Wear appropriate clothes while exercising; do not wear loose clothes that could become caught on the elliptical. Always wear athletic shoes for foot protection while exercising.
15. Hold the handlebars or the upper body arms when mounting, dismounting, or using the elliptical.
16. The heart rate monitor is not a medical device. Various factors may affect the accuracy of heart rate readings. The heart rate monitor is intended only as an exercise aid in determining heart rate trends in general.
17. The elliptical does not have a freewheel; the pedals will continue to move until the flywheel stops. Reduce your pedaling speed in a controlled way.
18. Keep your back straight while using the elliptical; do not arch your back.
19. Over exercising may result in serious injury or death. If you feel faint or if you experience pain while exercising, stop immediately and cool down.

**SAVE THESE INSTRUCTIONS**

# MAKE YOUR FITNESS GOALS A **REALITY**

**iFIT**<sup>®</sup>

Congratulations on the purchase of your new iFit<sup>®</sup> compatible fitness equipment. You're just one click away from making your fitness goals a reality.

**GO TO IFIT.COM TO GET STARTED**

## **DO MORE THAN JUST WORK OUT**

iFit<sup>®</sup> is the most powerful training tool available to help you accomplish all of your fitness goals. From weight loss and performance to personalized training programs, iFit<sup>®</sup> is the key to getting more out of everything you do. Some features require paid subscription.



### **LOSE WEIGHT**

Stay on track and motivated with progressive weight loss programs with our trainers, including Jillian Michaels.



### **COMPETE WITH OTHERS**

Push yourself to new limits with real-time virtual races.



### **PERSONALIZED EVENT TRAINING**

5k, 10k, half or full marathon training will help you prepare for your event.



### **GO MOBILE**

Track your workout anywhere you go with iFit<sup>®</sup> mobile apps.



### **MAP YOUR ROUTE**

With Google Maps<sup>™</sup>, your fitness equipment will simulate the earth's terrain while displaying Street View during your workout.



### **SHARE YOUR PROGRESS**

Inspire others, motivate yourself and share routes, workouts and more.

GO TO  
**IFIT.COM**

OR CALL  
**877-236-1009**

# PROTECT

YOUR FITNESS EQUIPMENT  
WITH AN EXTENDED SERVICE PLAN

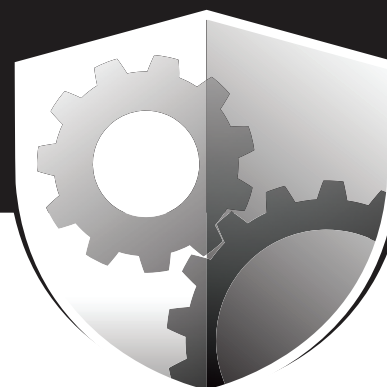

Your new fitness equipment is not an ordinary purchase; it is an investment in your health and well being for years to come.

As the leading provider of manufacturer's extended service plans, ICON strives to protect your equipment and your future.

Please review the following service plans and find one that best fits your needs.

## PREVENTIVE MAINTENANCE SERVICE PLANS

Equipment Price	3-Year Plan	5-Year Plan
\$0.00 to \$1000.00	\$199.99	\$289.99
\$1001.00 to \$1500.00	\$259.99	\$379.99
\$1501.00 to \$2500.00	\$339.99	\$489.99
(Bikes/Systems Only) \$0.00 to \$2500.00	\$139.99	NA

### Features:

- Includes an annual preventive maintenance and performance check at your convenience
- Unlimited in-home repairs; no shipping required
- Covers parts and labor on all manufacturer's defects, as well as wear and tear on parts
- Up to 5 years of coverage available

## STANDARD SERVICE PLANS

Equipment Price	1-Year Plan	2-Year Plan	3-Year Plan
\$0.00 to \$300.00	\$29.99	\$39.99	\$59.99
\$301.00 to \$1000.00	\$89.99	\$119.99	\$149.99
\$1001.00 to \$2000.00	\$109.99	\$139.99	\$179.99
\$2001.00 to \$3000.00	\$179.99	\$209.99	\$239.99

### Features:

- Unlimited in-home repairs; no shipping required
- Covers parts and labor on all manufacturer's defects, as well as wear and tear on parts
- Up to 3 years of coverage available

To protect your fitness equipment today, please  
call Customer Care at **1-800-677-3838.**  
Or, visit us online at **www.utserv.com.**



# BEFORE YOU BEGIN

Thank you for selecting the revolutionary NORDICTRACK® E 11.7 elliptical. The E 11.7 elliptical provides an impressive selection of features designed to make your workouts at home more effective and enjoyable.

**For your benefit, read this manual carefully before you use the elliptical.** If you have questions after

reading this manual, please see the front cover of this manual. To help us assist you, note the product model number and serial number before contacting us. The model number and the location of the serial number decal are shown on the front cover of this manual.

Before reading further, please familiarize yourself with the parts that are labeled in the drawing below.

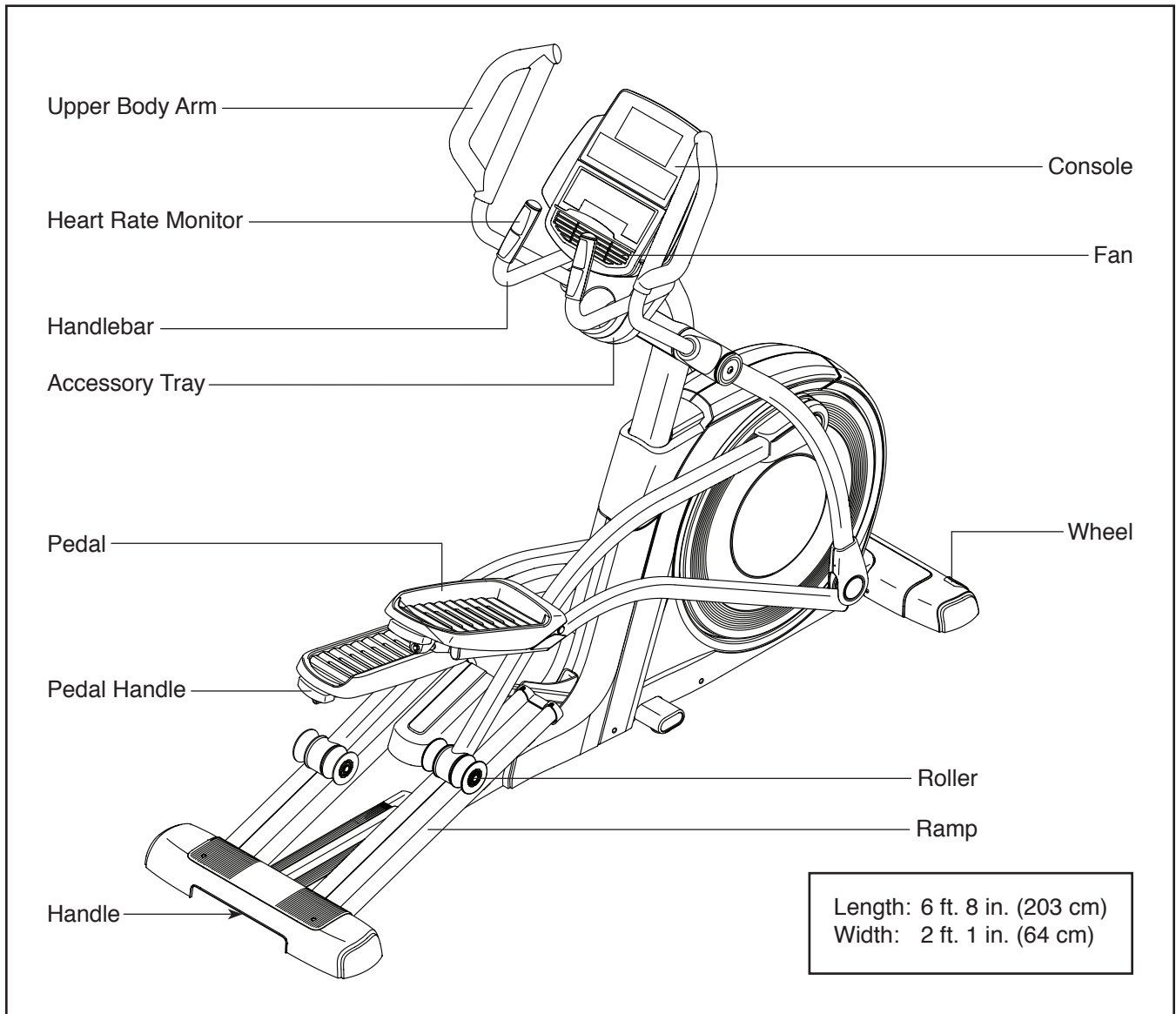

# PART IDENTIFICATION CHART

Use the drawings below to identify the small parts needed for assembly. The number in parentheses below each drawing is the key number of the part, from the PART LIST near the end of this manual. The number following the key number is the quantity needed for assembly. **Note: If a part is not in the hardware kit, check to see if it has been preassembled. Extra parts may be included.**

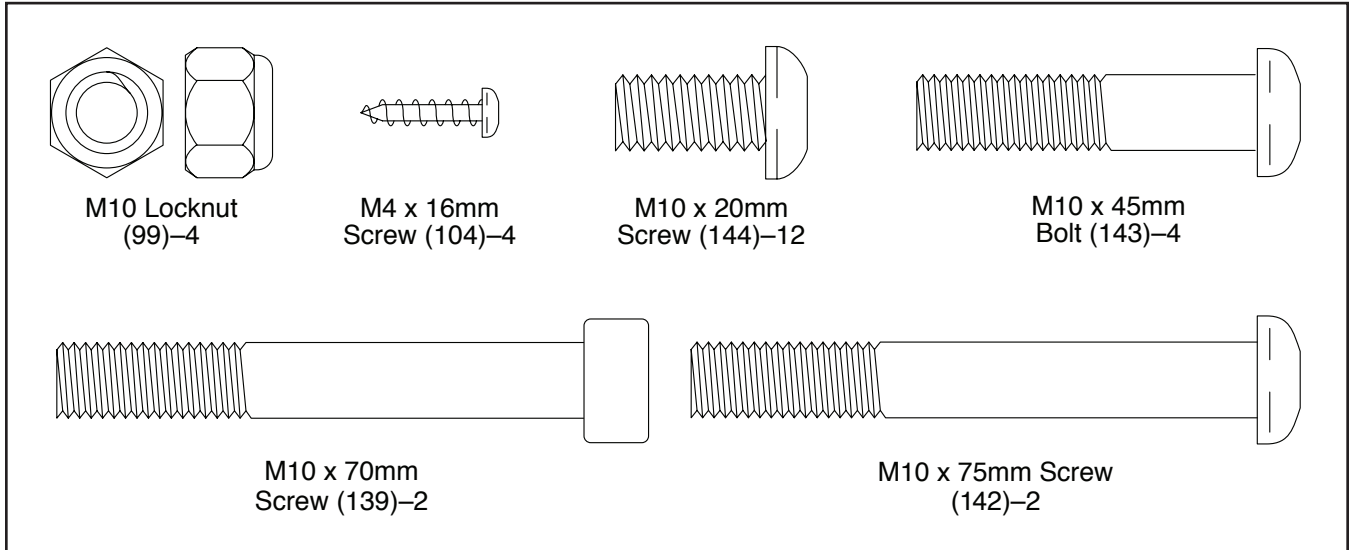

# ASSEMBLY

- Assembly requires two persons.
- Place all parts in a cleared area and remove the packing materials. Do not dispose of the packing materials until you complete all assembly steps.
- Left parts are marked “L” or “Left” and right parts are marked “R” or “Right.”
- To identify small parts, see page 7.

- In addition to the included tool(s), assembly requires the following tools:

one Phillips screwdriver 

one adjustable wrench 

Assembly may be easier if you have your own set of wrenches. To avoid damaging parts, do not use power tools.

1. **Go to [www.nordictrackservice.com/](http://www.nordictrackservice.com/) registration on your computer and register your product.**

Registration provides the following benefits:

- activates your product manufacturer’s warranty
- saves you time if you ever need to contact Customer Care
- allows us to notify you of upgrades and offers

Note: If you do not have Internet access, call Customer Care (see the front cover of this manual) to register your product.

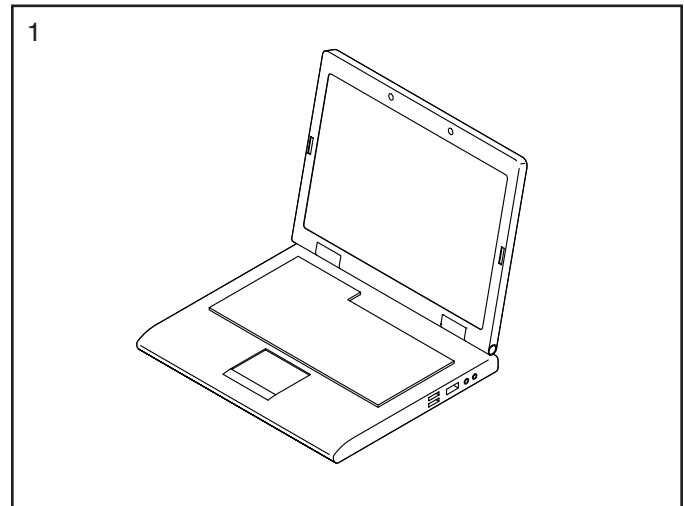

2. With the help of a second person, place some of the packing materials (not shown) under the rear of the Frame (1). **Have the second person hold the Frame to prevent it from tipping while you complete this step.**

Identify the two Rear Stabilizers (5).

Attach one of the Rear Stabilizers (5) to the Frame (1) with three M10 x 20mm Screws (144); **start all three Screws, and then tighten them.**

**Attach the other Rear Stabilizer (5) in the same way.**

Then, remove the packing materials from under the Frame (1).

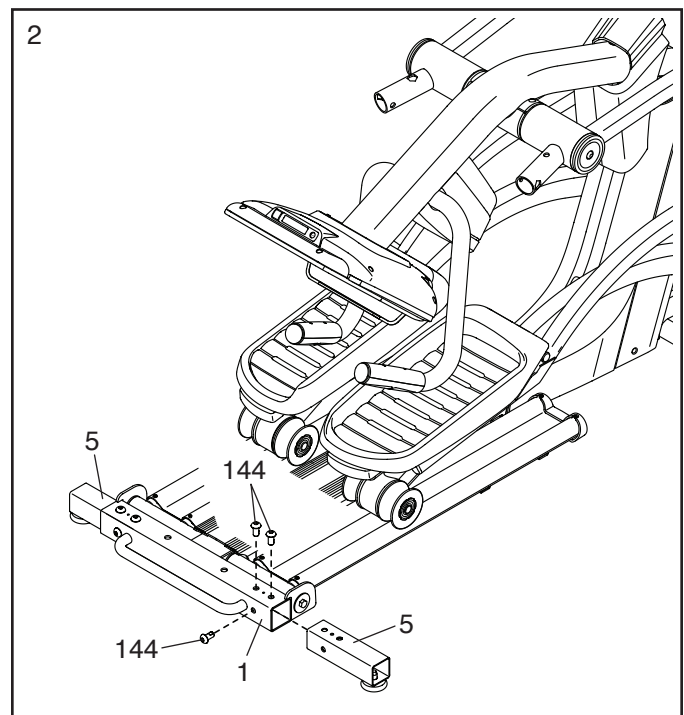



3. Orient the Rear Stabilizer Cover (2) as shown, and press it onto the Frame (1).

Attach the Rear Stabilizer Cover (2) with two M4 x 16mm Screws (104).

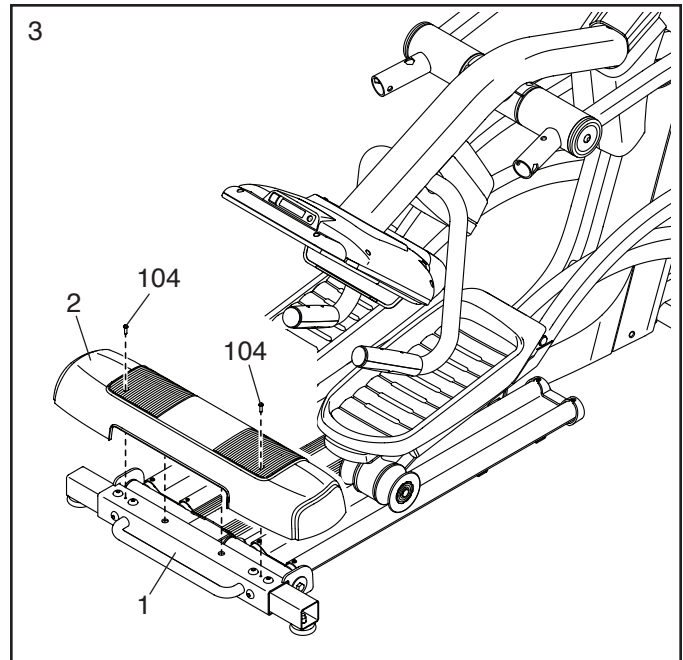

4. With the help of a second person, place some of the packing materials (not shown) under the front of the Frame (1). **Have the second person hold the Frame to prevent it from tipping while you complete this step.**

Identify the Right Front Stabilizer (6) and orient it as shown.

Attach the Right Front Stabilizer (6) to the Frame (1) with three M10 x 20mm Screws (144); **start all three Screws, and then tighten them.**

**Attach the Left Front Stabilizer (not shown) in the same way.**

Then, remove the packing materials from under the Frame (1).

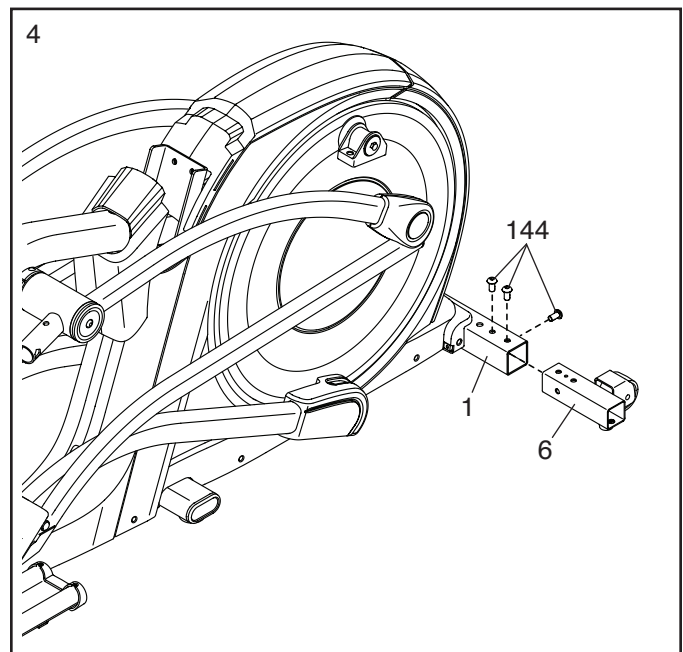

5. Orient the Front Stabilizer Cover (8) as shown, and press it onto the Frame (1).

Attach the Front Stabilizer Cover (8) with two M4 x 16mm Screws (104).

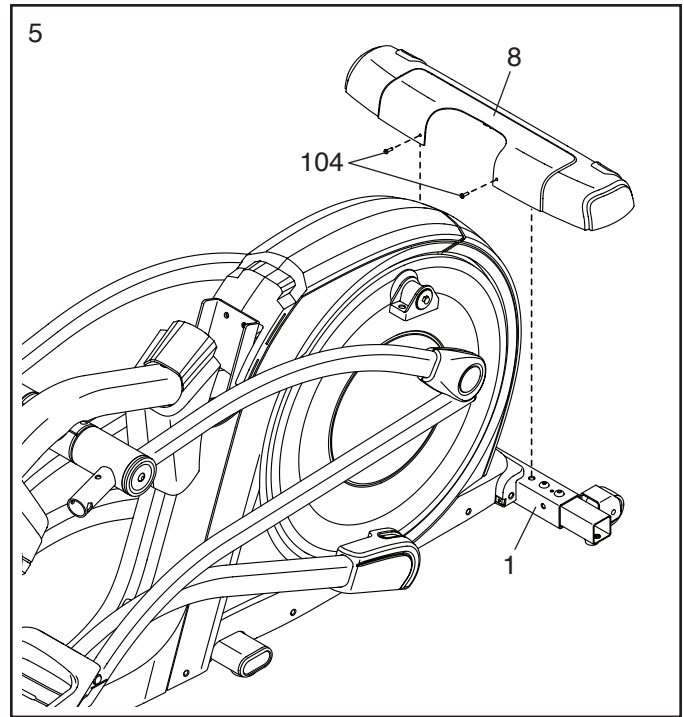

6. Raise the Upright (4) to the vertical position. Secure the Upright with two M10 x 75mm Screws (142).

Then, slide the Shield Cover (56) downward onto the Rear Shield (75).

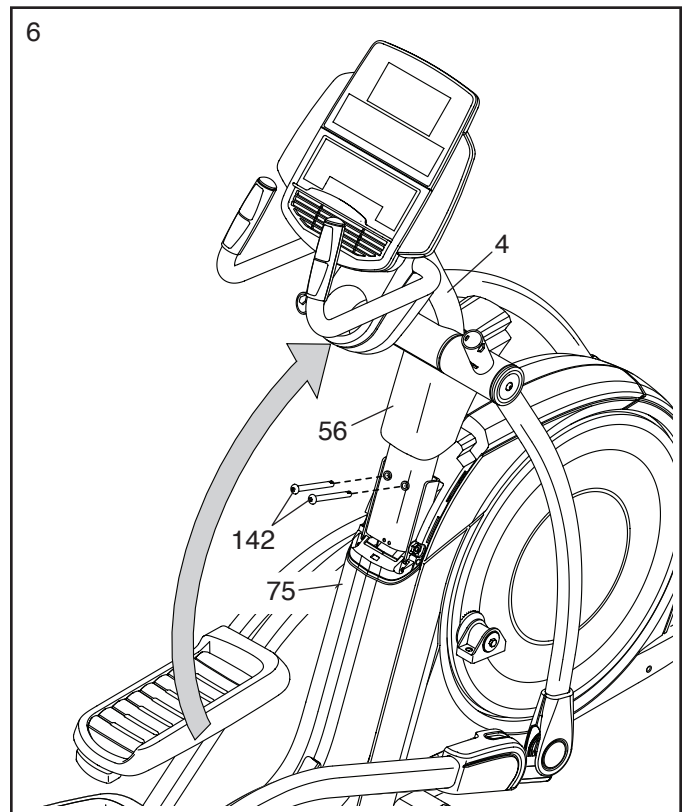

7. Locate the Right Upper Saddle Bracket (121) on the Right Roller Arm (45). Next, locate the Lower Saddle Bracket (26) on the right side of the elliptical.

Attach the Right Upper Saddle Bracket (121) to the Lower Saddle Bracket (26) with two M10 x 70mm Screws (139).

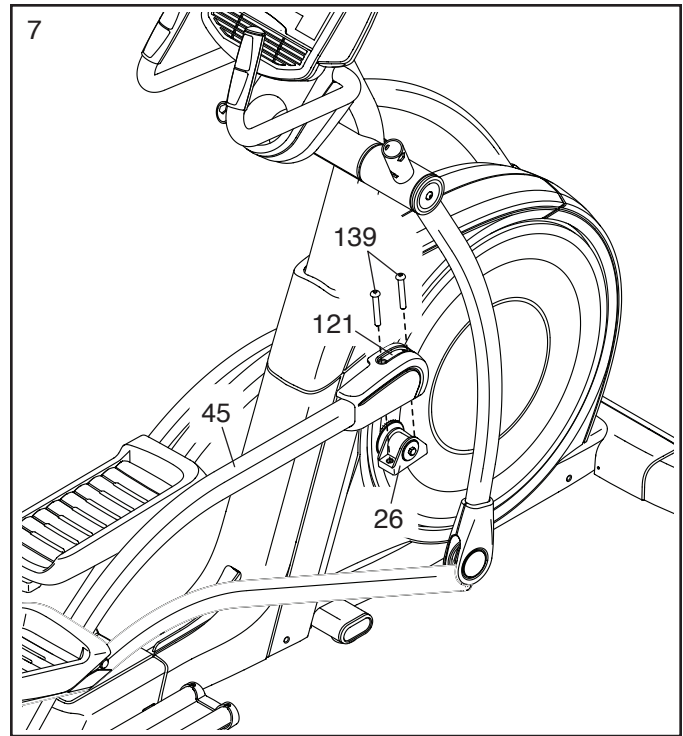

8. Identify the Right Upper Body Arm (61) and an Upper Body Arm Cover (77). Slide the Upper Body Arm Cover onto the Right Upper Body Arm as shown.

Attach the Right Upper Body Arm (61) to the Right Upper Body Leg (36) with two M10 x 45mm Bolts (143) and two M10 Locknuts (99); **make sure that the Locknuts are in the hexagonal holes.**

Then, slide the Upper Body Arm Cover (77) downward and turn it so that it is flush with the Right Upper Body Leg (36).

**Attach the Left Upper Body Arm (47) in the same way.**

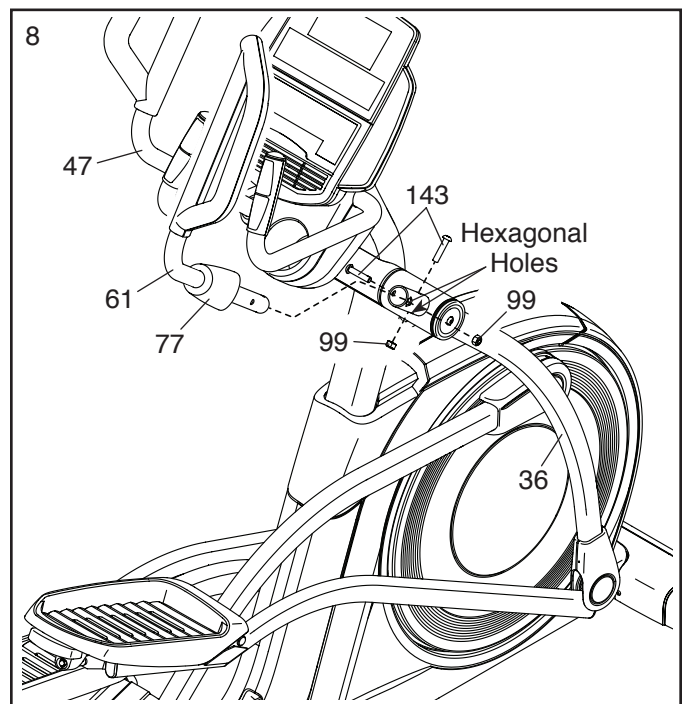

9. **Make sure that all parts are properly tightened before you use the elliptical.** Note: Extra parts may be included. Place a mat beneath the elliptical to protect the floor.

# THE CHEST HEART RATE MONITOR

## HOW TO PUT ON THE HEART RATE MONITOR

The heart rate monitor consists of a chest strap and a sensor. Insert the tab on one end of the chest strap into the hole in one end of the sensor as shown. Then, press the end of the sensor under the buckle on the chest strap. The tab should be flush with the front of the sensor.

The heart rate monitor must be worn under your clothes, tight against your skin. Wrap the heart rate monitor around your chest in the location shown. Make sure that the logo is right-side-up. Then, attach the other end of the chest strap to the sensor. Adjust the length of the chest strap, if necessary.

Pull the sensor away from your body a few inches and locate the two electrode areas, which are covered by shallow ridges. Using saline solution such as saliva or contact lens solution, wet the electrode areas. Then, return the sensor to a position against your chest.

## CARE AND MAINTENANCE

- Thoroughly dry the sensor with a soft towel after each use. Moisture may keep the sensor activated, shortening the life of the battery.
- Store the heart rate monitor in a warm, dry place. Do not store the heart rate monitor in a plastic bag or other container that may trap moisture.

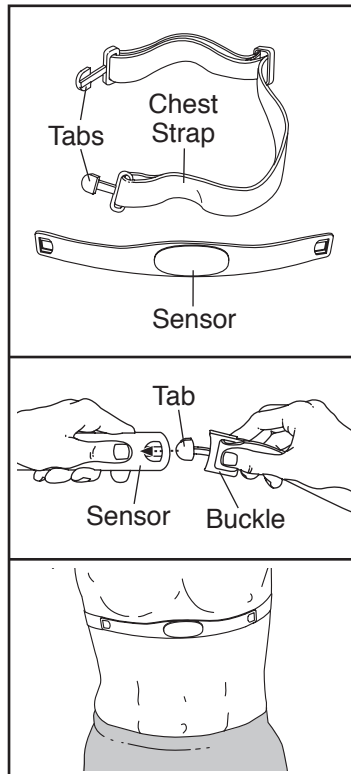

- Do not expose the heart rate monitor to direct sunlight for extended periods of time; do not expose it to temperatures above 122° F (50° C) or below 14° F (-10° C).
- Do not excessively bend or stretch the sensor when using or storing the heart rate monitor.
- To clean the sensor, use a damp cloth and a small amount of mild soap. Then, wipe the sensor with a damp cloth and thoroughly dry it with a soft towel. Never use alcohol, abrasives, or chemicals to clean the sensor. Hand wash and air dry the chest strap.

## TROUBLESHOOTING

If the heart rate monitor does not function properly, try the steps below.

- Make sure that you are wearing the heart rate monitor as described at the left. If the heart rate monitor does not function when positioned as described, move it slightly lower or higher on your chest.
- If heart rate readings are not displayed until you begin perspiring, rewet the electrode areas.
- For the console to display heart rate readings, you must be within arm's length of the console.
- If there is a battery cover on the back of the sensor, replace the battery with a new battery of the same type.
- The heart rate monitor is designed to work with people who have normal heart rhythms. Heart rate reading problems may be caused by medical conditions such as premature ventricular contractions (pvc's), tachycardia bursts, and arrhythmia.
- The operation of the heart rate monitor can be affected by magnetic interference from high power lines or other sources. If you suspect that magnetic interference is causing a problem, try relocating the fitness equipment.

# HOW TO USE THE ELLIPTICAL

## HOW TO PLUG IN THE POWER CORD

**This product must be grounded.** If it should malfunction or break down, grounding provides a path of least resistance for electric current to reduce the risk of electric shock. The power cord has a plug with a grounding pin.

**⚠ DANGER:** Improper connection of the power cord increases the risk of electric shock. Do not modify the plug; if it will not fit an outlet, have a proper outlet installed by a qualified electrician. If you are unsure whether the product is properly grounded, contact a qualified electrician.

Plug the power cord into an appropriate outlet that is properly installed and grounded in accordance with all local codes and ordinances. The outlet must be on a nominal 120-volt circuit.

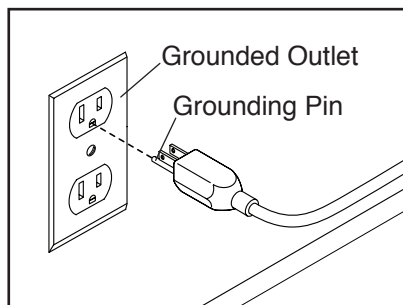

A temporary adapter may be used to connect the power cord to a 2-pole receptacle as shown at the right if a properly grounded outlet is not available.

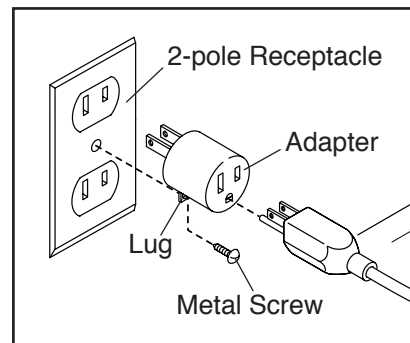

The lug or wire extending from the adapter must be connected with a metal screw to a permanent ground such as a properly grounded outlet box cover. **Some 2-pole receptacle outlet box covers are not grounded. Before using an adapter, contact a qualified electrician to determine whether the outlet box cover is grounded before using an adapter. The temporary adapter should be used only until a properly grounded outlet can be installed by a qualified electrician.**

## HOW TO ADJUST THE POSITIONS OF THE PEDALS

Each pedal can be adjusted to several positions. To adjust each pedal, simply pull the pedal handle outward, move the pedal to the desired position, and then release the pedal handle into an adjustment hole beneath the pedal. **Make sure to adjust both pedals to the same position.**

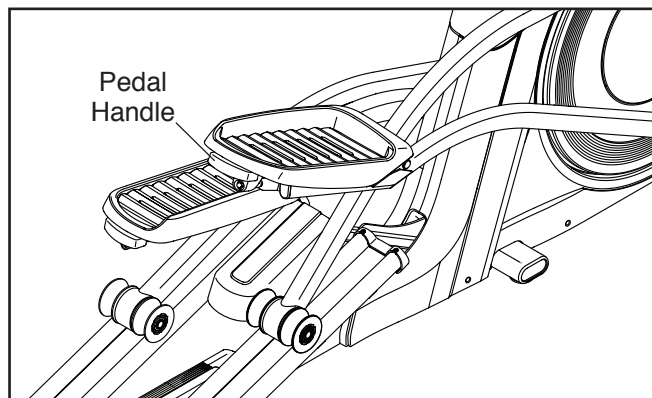

## HOW TO MOVE THE ELLIPTICAL

Due to the size and weight of the elliptical, moving it requires two persons. Stand in front of the elliptical, hold the upright, and place one foot against one of the wheels. Have a second person lift the handle on the rear of the frame until the elliptical will roll on the wheels. Carefully move the elliptical to the desired location, and then lower it to the floor.

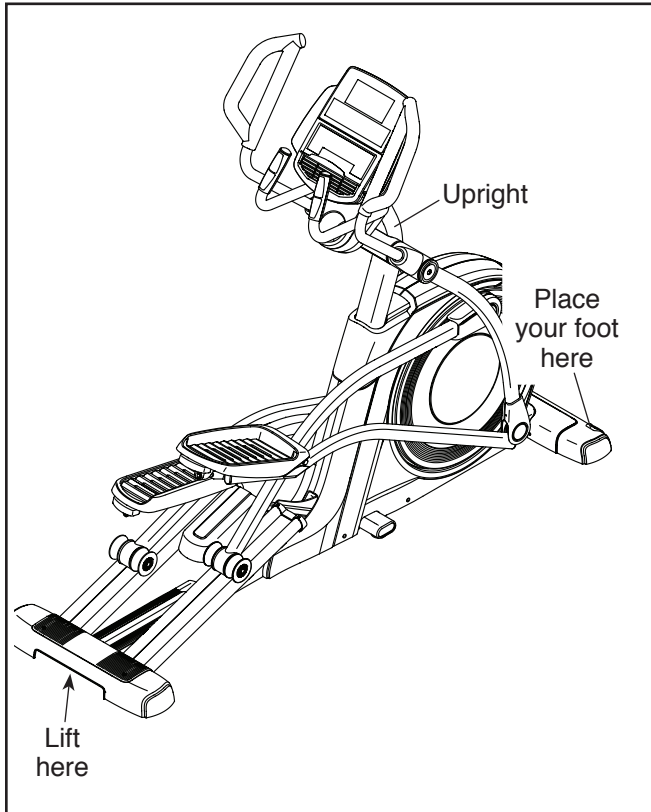

## HOW TO EXERCISE ON THE ELLIPTICAL

To mount the elliptical, hold the upper body arms or the handlebars and step onto the pedal that is in the lower position. Then, step onto the other pedal. Push the pedals until they begin to move with a continuous motion. **Note: The crank arms can turn in either direction. It is recommended that you turn the crank arms in the direction shown by the arrow; however, for variety, you can turn the crank arms in the opposite direction.**

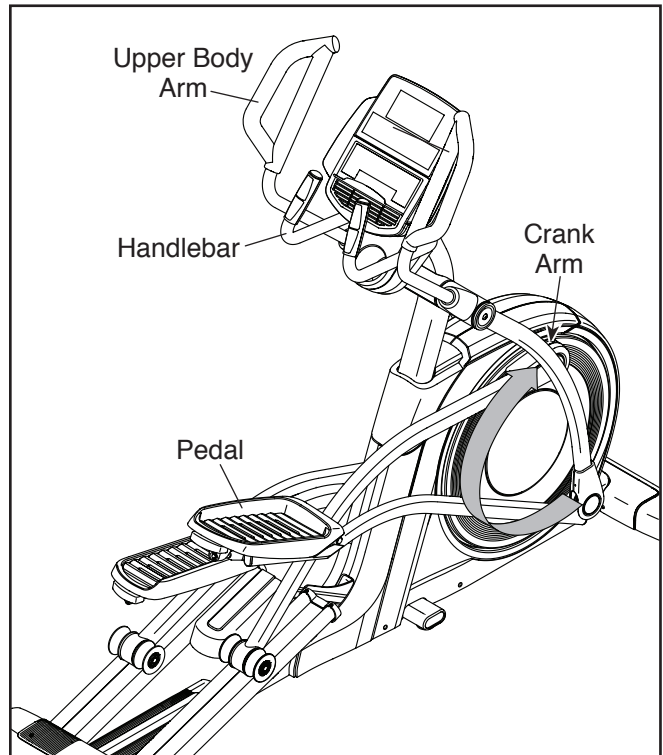

## HOW TO LEVEL THE ELLIPTICAL

If the elliptical rocks slightly on your floor during use, turn one or both of the leveling feet beneath the rear stabilizer or beneath the frame until the rocking motion is eliminated.

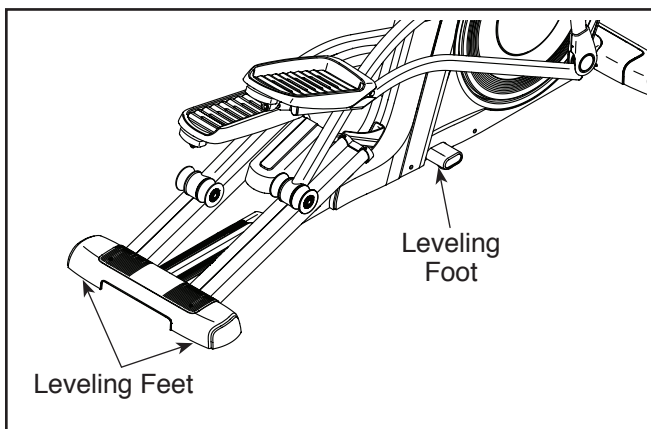

To dismount the elliptical, wait until the pedals come to a complete stop. **Note: The elliptical does not have a free wheel; the pedals will continue to move until the flywheel stops.** When the pedals are stationary, step off the higher pedal first. Then, step off the lower pedal.

## CONSOLE DIAGRAM

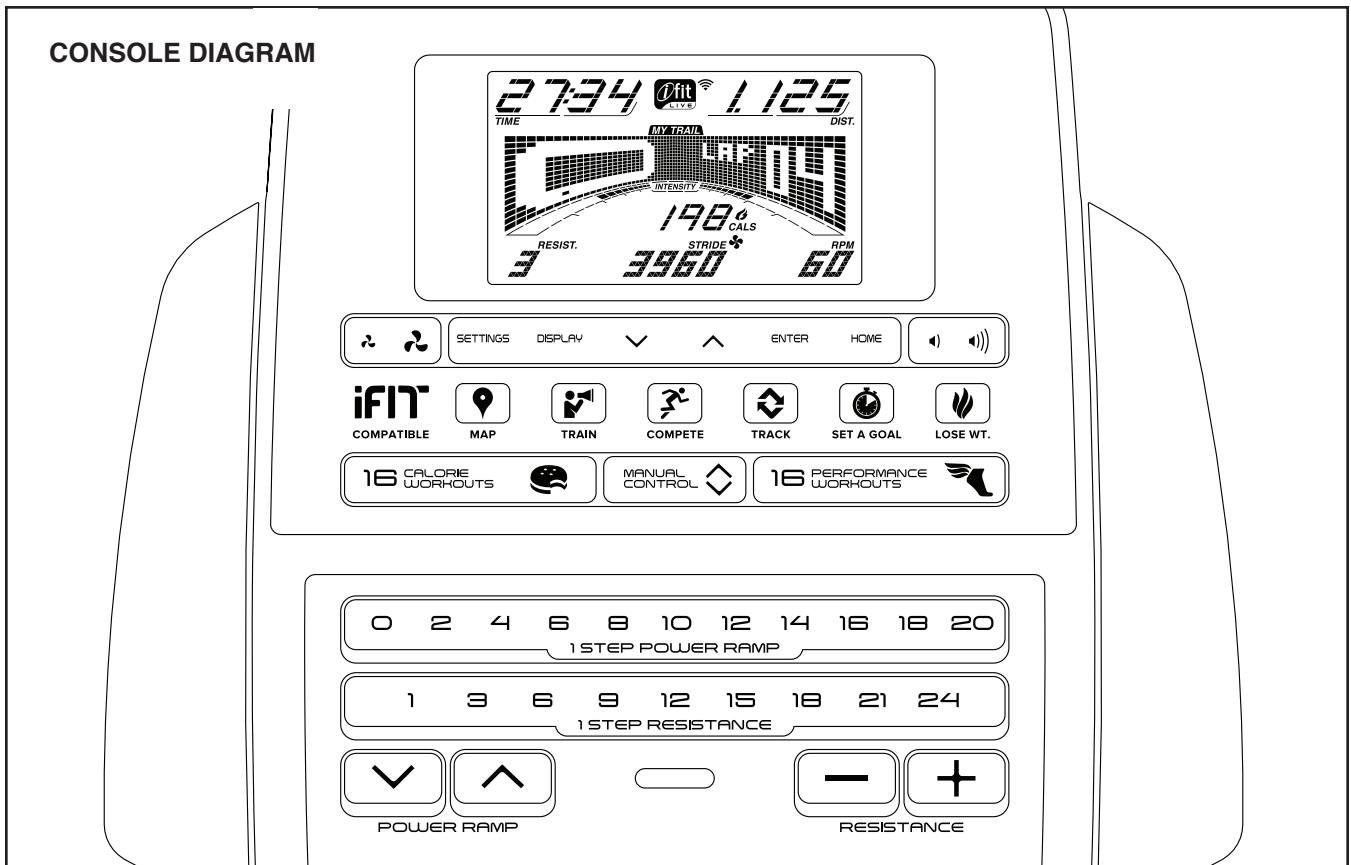

### MAKE YOUR FITNESS GOALS A REALITY WITH IFIT.COM

With your new iFit-compatible fitness equipment, you can use an array of features on iFit.com to make your fitness goals a reality:



Exercise anywhere in the world with customizable Google Maps.



Download training workouts designed to help you reach your personal goals.



Measure your progress by competing against other users in the iFit community.



Upload your workout results to the iFit cloud and track your accomplishments.



Set calorie, time, or distance goals for your workouts.



Choose and download sets of weight-loss workouts

**Go to [iFit.com](http://iFit.com) to learn more.**

## FEATURES OF THE CONSOLE

The advanced console offers an array of features designed to make your workouts more effective and enjoyable.

When you use the manual mode of the console, you can change the resistance of the pedals with the touch of a button.

While you exercise, the console will display continuous exercise feedback. You can even measure your heart rate using the handgrip heart rate monitor or the included chest heart rate monitor.

The console also offers a selection of onboard workouts. Each workout automatically changes the resistance of the pedals as it guides you through an effective workout. You can even set a customized workout goal with the set-a-goal workout.

The console also features an iFit mode that enables the console to communicate with your wireless network through an optional iFit module. With the iFit mode, you can download personalized workouts, create your own workouts, track your workout results, race against other iFit users, and access many other features. **To purchase an iFit module at any time, go to [www.iFit.com](http://www.iFit.com) or call the telephone number on the front cover of this manual.**

You can even connect your MP3 player or CD player to the console sound system and listen to your favorite music or audio books while you exercise.

**To use the manual mode**, see page 17. **To use an onboard workout**, see page 19. **To use a set-a-goal workout**, see page 20. **To use an iFit workout**, see page 21. **To change console settings**, see page 22. **To use the sound system**, see page 22.

Note: If there is a sheet of plastic on the display, remove the plastic.

## HOW TO TURN ON THE POWER

**IMPORTANT: If the elliptical has been exposed to cold temperatures, allow it to warm to room temperature before you turn on the power. If you do not do this, you may damage the console displays or other electrical components.**

Plug in the power cord (see HOW TO PLUG IN THE POWER CORD on page 13). Next, locate the power switch on the frame near the power cord. Press the power switch to the reset position.

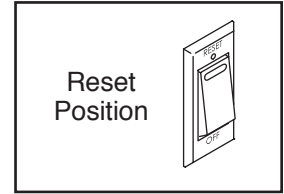

The display will then turn on and the console will be ready for use.

**Note: When you turn on the power for the first time, the incline of the ramp may calibrate automatically.** The ramp will move upward and downward as it calibrates. When the ramp stops moving, the ramp is calibrated.

**IMPORTANT: If the incline of the ramp does not calibrate automatically, see HOW TO CALIBRATE THE RAMP on page 24 and manually calibrate the ramp.**

**IMPORTANT: The console features a display demo mode, designed to be used if the elliptical is displayed in a store. If the demo mode is turned on, the console will not turn off and the display will not be reset when you finish exercising. To turn off the demo mode, see step 3 on page 22.**



## HOW TO USE THE MANUAL MODE

### 1. Begin pedaling or press any button on the console to turn on the console.

See HOW TO TURN ON THE POWER on page 16.

### 2. Select the manual mode.

Press the Manual Control button on the console to select the manual mode.

Note: If an iFit module is not inserted into the console and connected to iFit.com, the manual mode will be selected automatically.

### 3. Change the resistance of the pedals and the incline of the ramp as desired.

As you pedal, change the resistance of the pedals by pressing the Resistance increase and decrease buttons or by pressing one of the numbered 1 Step Resistance buttons on the console.

Note: After you press a button, it will take a moment for the pedals to reach the selected resistance level.

To vary the motion of the pedals, you can change the incline of the ramp. To change the incline, press the Power Ramp increase and decrease buttons or press one of the numbered 1 Step Power Ramp buttons.

Note: After you press a button, it will take a moment for the ramp to reach the selected incline level.

### 4. Follow your progress with the display.

The display can show the following workout information:

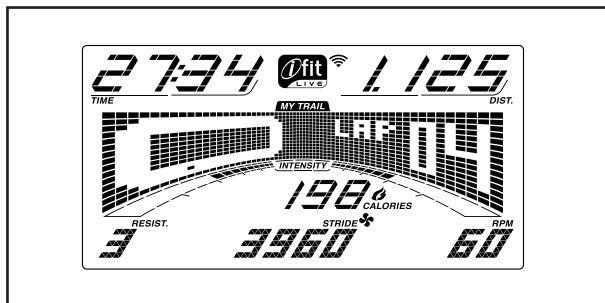

**Calories**—This display mode will show the approximate number of calories you have burned.

**Calories per Hour (Calories/Hr)**—This display mode will show the approximate number of calories you are burning per hour.

**Distance (Dist.)**—This display mode will show the distance that you have pedaled in miles or kilometers.

**Pulse**—This display mode will show your heart rate when you use the handgrip heart rate monitor or the included chest heart rate monitor (see step 5).

**Ramp**—This display mode will show the incline level of the ramp for a few seconds each time the incline level changes.

**Resistance (Resist.)**—This display mode will show the resistance level of the pedals for a few seconds each time the resistance level changes.

**RPM**—This display mode will show your pedaling speed in revolutions per minute (rpm).

**Stride**—This display mode will show the total number of strides you have pedaled.

**Time**—When the manual mode is selected, this display mode will show the elapsed time. When an onboard workout is selected, this display mode will show the time remaining in the workout.

The matrix offers several display tabs. Press the Display button until the desired tab is shown. You can also press the increase and decrease buttons next to the Enter button.

**Speed**—This tab will show a profile of the speed settings of the workout. A new segment will appear at the end of each minute.

**My Trail**—This tab will show a track that represents 1/4 mile (400 m). As you exercise, the flashing rectangle will show your progress. The My Trail tab will also show the number of laps you complete.

**Calorie**—This tab will show the approximate amount of calories you have burned. The height of each segment represents the amount of calories burned during that segment.

**Incline**—This tab will show a profile of the incline settings of the workout. A new segment will appear at the end of each minute.

As you exercise, the workout intensity level bar will indicate the approximate intensity level of your exercise.

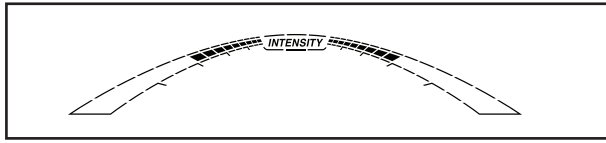

Press the Home button to return to the default menu (see HOW TO CHANGE CONSOLE SETTINGS on page 22 to set the default menu). If necessary, press the Home button again.

When a wireless iFit module is connected, the wireless symbol at the top of the display will show the strength of your wireless signal. Four arcs indicate full signal strength.



Change the volume level of the console by pressing the volume increase and decrease buttons.



## 5. Measure your heart rate if desired.

To use the included chest heart rate monitor, see page 12. To use the handgrip heart rate monitor, follow the instructions below. **IMPORTANT: If you use both heart rate monitors at the same time, the console will not display your heart rate accurately.**

**If there are sheets of plastic on the metal contacts on the handgrip heart rate monitor, remove the plastic.** To measure your heart rate, hold the handgrip heart rate monitor with your palms resting against the contacts. **Avoid moving your hands or gripping the contacts tightly.**

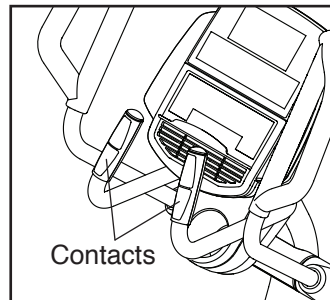

When your pulse is detected, a heart symbol will flash in the display each time your heart beats, one or two dashes will appear, and then your heart rate will be shown. **For the most accurate heart rate reading, hold the contacts for at least 15 seconds.**

If the display does not show your heart rate, make sure that your hands are positioned as described. Be careful not to move your hands excessively or to squeeze the contacts tightly. For optimal performance, clean the contacts using a soft cloth; **never use alcohol, abrasives, or chemicals to clean the contacts.**

## 6. Turn on the fan if desired.

The fan has low, high, and auto settings. While the auto mode is selected, the speed of the fan will automatically change as you change your pedaling speed. Press the fan increase and decrease buttons repeatedly to select a fan setting or to turn off the fan.



Note: If the pedals do not move for about thirty seconds, the fan will turn off automatically.

## 7. When you are finished exercising, unplug the power cord.

If the pedals do not move for several seconds, a tone will sound and the console will pause.

If the pedals do not move for several minutes and the buttons are not pressed, the console will turn off and the display will be reset.

When you are finished exercising, press the power switch to the off position and unplug the power cord. **IMPORTANT: If you do not do this, the electrical components on the elliptical may wear prematurely.**

## HOW TO USE AN ONBOARD WORKOUT

### 1. Begin pedaling or press any button on the console to turn on the console.

See HOW TO TURN ON THE POWER on page 16.

### 2. Select an onboard workout.

To select an onboard workout, press the Calorie Workouts button or the Performance Workouts button repeatedly until the desired workout appears in the display.

When you select an onboard workout, the display will show the duration of the workout and the name of the workout. A profile of the speed settings of the workout will appear in the matrix.

The display will also show the maximum pedaling speed (rpm), the maximum resistance level, and the maximum ramp incline level.

### 3. Begin pedaling to start the workout.

Each workout is divided into one-minute segments. One resistance level, one ramp incline level, and one target rpm (speed) are programmed for each segment. Note: The same resistance level, ramp incline level, and/or target rpm may be programmed for consecutive segments.

The resistance level, the ramp incline level, and the target rpm for the first segment will appear in the matrix.

During the workout, the profiles on the speed and incline tabs will show your progress.

The flashing segment of the profile represents the current segment of the workout. The height of the flashing segment indicates the target speed or the incline level for the current segment.

At the end of each segment of the workout, a series of tones will sound and the next segment of

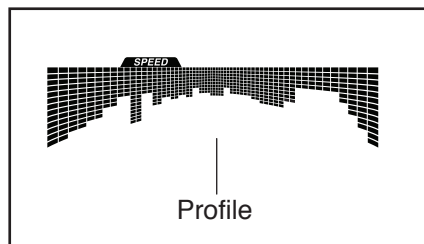

the profile will begin to flash. If a different resistance level, ramp incline level, and/or target rpm is programmed for the next segment, the resistance level, ramp incline level, and/or target rpm will appear in the display for a few seconds to alert you. The resistance of the pedals and the incline level of the ramp will then change.

As you exercise, you will be prompted to keep your pedaling speed near the target rpm for the current segment. **When an upward-pointing arrow appears in the display**, increase your pace. **When a downward-pointing arrow appears**, decrease your pace. **When no arrow appears**, maintain your current pace.

**IMPORTANT: The target rpm is intended only to provide motivation. Your actual pedaling speed may be slower than the target rpm. Make sure to pedal at a speed that is comfortable for you.**

If the resistance level or incline level for the current segment is too high or too low, you can manually override the setting by pressing the Resistance buttons or the Power Ramp buttons. **IMPORTANT: When the current segment of the workout ends, the pedals will automatically adjust to the resistance level programmed for the next segment and the ramp will automatically adjust to the incline level programmed for the next segment.**

The workout will continue in this way until the last segment ends. To stop the workout at any time, stop pedaling. The time will flash in the display. To resume the workout, simply resume pedaling.

### 4. Follow your progress with the display.

See step 4 on page 17.

### 5. Measure your heart rate if desired.

See step 5 on page 18.

### 6. Turn on the fan if desired.

See step 6 on page 18.

### 7. When you are finished exercising, unplug the power cord.

See step 7 on page 18.

## HOW TO USE A SET-A-GOAL WORKOUT

- 1. Begin pedaling or press any button on the console to turn on the console.**

See HOW TO TURN ON THE POWER on page 16.

- 2. Set a calorie, distance, or time goal.**

To set a calorie, distance, or time goal, first press the Set A Goal button.

Next, press the increase and decrease buttons next to the Enter button until the name of the desired goal appears in the display. Then, press the Enter button.

Then, press the increase and decrease buttons next to the Enter button to set the desired goal.

- 3. Begin pedaling to start the workout.**

Each workout is divided into one-minute segments.

You can manually change the resistance of the pedals and incline of the ramp as desired during the workout by pressing the Resistance buttons and the Power Ramp buttons.

**Note:** If you manually change the resistance level or the ramp incline level during a calorie goal workout, the length of the workout will adjust automatically to ensure that you meet your calorie goal.

**Note:** The calorie goal is an estimate of the number of calories that you will burn during the workout. The actual number of calories that you burn will depend on various factors such as your weight. In addition, if you manually change the resistance level or the ramp incline level during the workout, the number of calories you burn will be affected.

The workout will continue in this way until the calorie, distance, or time goal is reached. To pause the workout, stop pedaling. The time will pause in the display. To resume the workout, simply resume pedaling.

- 4. Follow your progress with the display.**

See step 4 on page 17.

- 5. Measure your heart rate if desired.**

See step 5 on page 18.

- 6. Turn on the fan if desired.**

See step 6 on page 18.

- 7. When you are finished exercising, unplug the power cord.**

See step 7 on page 18.

## HOW TO USE AN iFIT WORKOUT

You must have an iFit module to use an iFit workout. **To purchase an iFit module at any time, go to [www.iFit.com](http://www.iFit.com) or call the telephone number on the front cover of this manual.**

Note: To use an iFit module, you must have access to a computer with an internet connection and a USB port. You will also need an iFit.com membership. To use a wireless iFit module, you must also have your own wireless network including an 802.11b/g/n router with SSID broadcast enabled (hidden networks are not supported).

### 1. Begin pedaling or press any button on the console to turn on the console.

See HOW TO TURN ON THE POWER on page 16.

### 2. Insert the iFit module into the console.

To use an iFit workout, make sure that the iFit module is inserted in the console.

**IMPORTANT: To satisfy exposure compliance requirements, the antenna and transmitter in the iFit module must be at least 8 in. (20 cm) from all persons and must not be near or connected to any other antenna or transmitter.**

### 3. Select a user.

If more than one user is registered on your iFit account, you can switch users in the iFit main screen. Press the increase and decrease buttons next to the Enter button to select a user.

### 4. Select an iFit workout.

To select an iFit workout, press one of the iFit buttons. Note: Before some workouts will download, you must add them to your schedule on [www.iFit.com](http://www.iFit.com).

Press the Map button, the Train button, or the Lose Wt. button to download the next workout of that type in your schedule.

Press the Compete button to compete in a race that you have previously scheduled.

Press the Track button to re-run a recent iFit workout from your schedule. Next, press the increase and decrease buttons to select the desired workout. Then, press the Enter button to start the workout.

**For more information about iFit workouts, please see [www.iFit.com](http://www.iFit.com).**

When you select an iFit workout, the display will show the duration of the workout and the approximate number of calories you will burn. The display may also show the name of the workout. If you select a competition workout, the display may count down to the beginning of the race.

Note: The iFit buttons may also run demo workouts. To use the demo workouts, remove the iFit module from the console and press one of the iFit buttons.

### 5. Start the workout.

See step 3 on page 19.

During some workouts, an audio coach will guide you through your workout. You can select a setting for the audio coach (see HOW TO CHANGE CONSOLE SETTINGS on page 22).

To stop the workout at any time, stop pedaling. The time will flash in the display. To resume the workout, simply resume pedaling.

### 6. Follow your progress with the display.

See step 4 on page 17.

The My Trail tab will show a map of the trail you are walking or running or it will show a track and the number of laps you complete.

During a competition workout, the Competition tab will show your progress in the race. As you race, the top line in the matrix will show how much of the race you have completed. The other lines will show other competitors. The end of the matrix represents the end of the race.

### 7. Measure your heart rate if desired.

See step 5 on page 18.

### 8. Turn on the fan if desired.

See step 6 on page 18.

### 9. When you are finished exercising, unplug the power cord.

See step 7 on page 18.

**For more information about iFit, go to [www.iFit.com](http://www.iFit.com).**

## HOW TO CHANGE CONSOLE SETTINGS

### 1. Select the settings mode.

To select the settings mode, press the Settings button.

The display will show the total number of hours that the elliptical has been used and the total distance (in miles or kilometers) that has been pedaled on the elliptical.

If an iFit module is connected to the console, the display will show the words WIFI MODULE or USB MODULE.

If no module is connected, the display will show the words NO IFIT MODULE. If no module is connected, some of the settings options will not be available.

### 2. Navigate the settings mode.

While the settings mode is selected, the matrix of the display will display several optional screens. Press the increase and decrease buttons next to the Enter button repeatedly to select the desired optional screen.

The lower section of the display will show instructions for the selected optional screen. **Make sure to follow the instructions shown in the lower part of the display.**

### 3. Change settings as desired.

**Demo**—The console features a display demo mode, designed to be used if the elliptical is displayed in a store. Press the Enter button repeatedly to turn the demo mode ON or OFF.

**Units**—The currently selected unit of measurement will appear in the display. To change the unit of measurement, press the Enter button repeatedly. To view distance in miles, select ENGLISH. To view distance in kilometers, select METRIC.

**Contrast Level**—The currently selected contrast level will appear in the display. Press the Power

Ramp increase and decrease buttons to adjust the contrast level.

The following additional settings will be available if an iFit module is inserted into the console.

**Trainer Voice**—The currently selected setting for the audio coach will appear in the display. Press the Enter button repeatedly to turn the audio coach ON or OFF.

**Default Menu**—The default menu will appear when you press the Home button. Press the Enter button repeatedly to select the manual mode or the iFit menu as the default menu.

**Check Status**—The words CHECK WIFI STATUS or CHECK USB STATUS will appear in the display. Press the Enter button. After a few seconds, the status of the iFit module will appear in the display. To exit this display, press the Settings button.

**Send/Receive**—The words SEND/RECEIVE DATA will appear in the display. Press the Enter button. The console will then check for iFit workouts and firmware downloads.

### 4. Exit the settings mode.

Press the Settings button to exit the settings mode.

## HOW TO USE THE SOUND SYSTEM

To play music or audio books through the console sound system while you exercise, plug a 3.5 mm male to 3.5 mm male audio cable (not included) into the jack on the console and into a jack on your MP3 player, CD player, or other personal audio player; **make sure that the audio cable is fully plugged in. Note: To purchase an audio cable, see your local electronics store.**

Next, press the play button on your personal audio player. Adjust the volume level using the volume increase and decrease buttons on the console or the volume control on your personal audio player.

---

## FCC INFORMATION

This equipment has been tested and found to comply with the limits for a Class B digital device, pursuant to part 15 of the FCC Rules. These limits are designed to provide reasonable protection against harmful interference in a residential installation. This equipment generates, uses, and can radiate radio frequency energy and, if not installed and used in accordance with the instructions, may cause harmful interference to radio communications. However, there is no guarantee that interference will not occur in a particular installation. If this equipment does cause harmful interference to radio or television reception, which can be determined by turning the equipment off and on, try to correct the interference by one or more of the following measures:

- Reorient or relocate the receiving antenna.
- Increase the separation between the equipment and the receiver.
- Connect the equipment into an outlet on a circuit different from that to which the receiver is connected.
- Consult the dealer or an experienced radio/TV technician for help.

**FCC CAUTION: To assure continued compliance, use only shielded interface cables when connecting to computer or peripheral devices. Changes or modifications not expressly approved by the party responsible for compliance could void the user's authority to operate this equipment.**

# MAINTENANCE AND TROUBLESHOOTING

Inspect and tighten all parts of the elliptical regularly. Replace any worn parts immediately.

To clean the elliptical, use a damp cloth and a small amount of mild soap. **IMPORTANT: To avoid damage to the console, keep liquids away from the console and keep the console out of direct sunlight.**

## CONSOLE TROUBLESHOOTING

If the console does not turn on, make sure that the power cord is fully plugged in.

If lines appear in the console display, see HOW TO CHANGE CONSOLE SETTINGS on page 22 and adjust the contrast level of the display.

If the console does not display your heart rate when you hold the handgrip heart rate monitor, or if the displayed heart rate appears to be too high or too low, see step 5 on page 18.

If the console does not display your heart rate when you use the chest heart rate monitor, see TROUBLESHOOTING on page 12.

## HOW TO GREASE THE ROLLERS

See the EXPLODED DRAWING near the end of this manual. If the Large Rollers (51) squeak when moving on the Tracks (11), apply a small amount of the included PTFE grease to a paper towel, and spread a thin layer of grease evenly along the Tracks. Then, wipe off any excess grease.

## HOW TO CALIBRATE THE RAMP

If the ramp is not functioning properly, the ramp may need to be calibrated. To calibrate the ramp, press and hold the Calorie Workouts button for several seconds until the test mode appears in the display.

Next, press the Calorie Workouts button again. Then, press the Power Ramp increase or decrease button to calibrate the ramp. The ramp will move upward and downward as it calibrates.

When the ramp stops moving, the ramp is calibrated. Then, press the Calorie Workouts button repeatedly to exit the calibration mode.

## HOW TO ADJUST THE REED SWITCH

If the console does not display correct feedback, the reed switch should be adjusted. To adjust the reed switch, first **unplug the power cord.**

Next, use a flat screwdriver and carefully pry the left Disc Cover (55) off the left Disc (71).

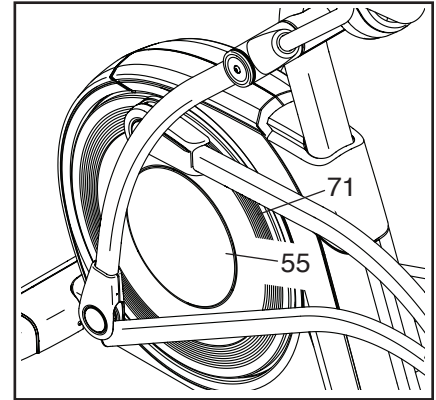

Next, turn the left Crank Arm (20) until one of the Magnets (43) on the Pulley (19) is aligned with the Reed Switch (38). Then, loosen, but do not remove, the two M4 x 16mm Screws (104), slide the Reed Switch (38) slightly closer to or away from the Magnet (43), and retighten the Screws.

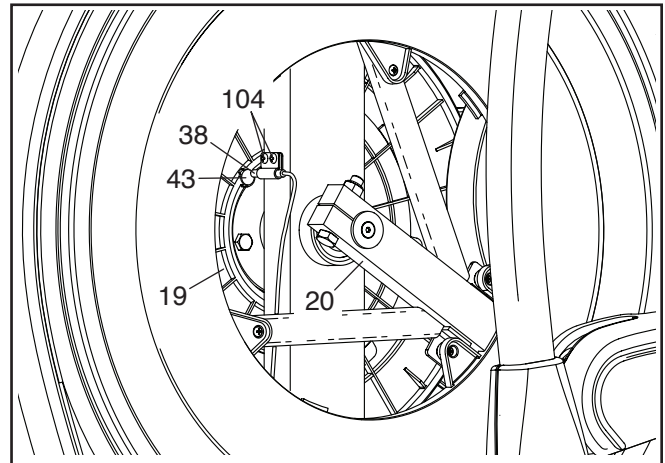

Then, plug in the power cord and turn the left crank arm for a moment. Repeat the procedure above, if necessary, until the console displays correct feedback. Then, reattach the left disc.



## HOW TO ADJUST THE DRIVE BELT

If the pedals slip while you are pedaling, even while the resistance is adjusted to the highest level, the drive belt may need to be adjusted. To adjust the drive belt, first **unplug the power cord**.

Next, use a flat screwdriver and pry off the Shield Cover (56) and slide it upward.

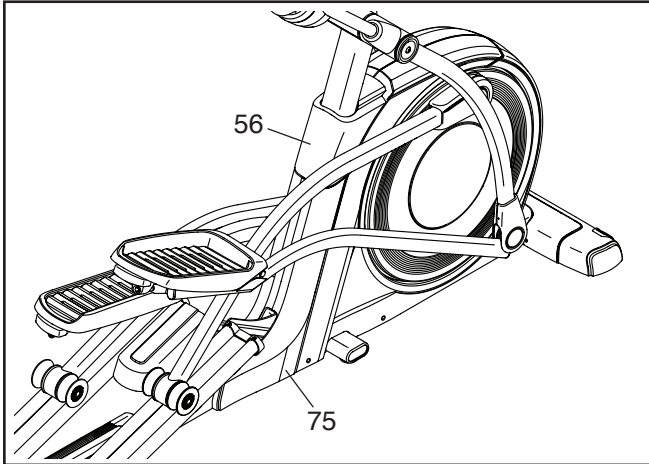

Then, remove the four M4 x 16mm Screws (not shown) from the upper and lower ends of the Rear Shield (75), and remove the Rear Shield.

Then, look between the Shields (73, 74) and locate the M8 Locknut (102). Tighten the Locknut until the Drive Belt (113) is tight.

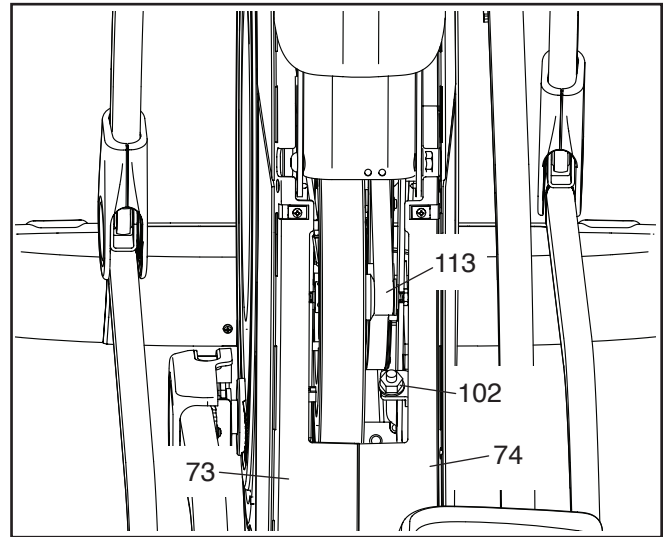

When you have properly adjusted the drive belt, reattach the rear shield and press the shield cover onto the rear shield.

# EXERCISE GUIDELINES

**⚠️ WARNING:** Before beginning this or any exercise program, consult your physician. This is especially important for persons over age 35 or persons with pre-existing health problems.

The heart rate monitor is not a medical device. Various factors may affect the accuracy of heart rate readings. The heart rate monitor is intended only as an exercise aid in determining heart rate trends in general.

These guidelines will help you to plan your exercise program. For detailed exercise information, obtain a reputable book or consult your physician. Remember, proper nutrition and adequate rest are essential for successful results.

## EXERCISE INTENSITY

Whether your goal is to burn fat or to strengthen your cardiovascular system, exercising at the proper intensity is the key to achieving results. You can use your heart rate as a guide to find the proper intensity level. The chart below shows recommended heart rates for fat burning and aerobic exercise.

165	155	145	140	130	125	115	♥
145	138	130	125	118	110	103	♥
125	120	115	110	105	95	90	♥
<hr/>							
20	30	40	50	60	70	80	

To find the proper intensity level, find your age at the bottom of the chart (ages are rounded off to the nearest ten years). The three numbers listed above your age define your “training zone.” The lowest number is the heart rate for fat burning, the middle number is the heart rate for maximum fat burning, and the highest number is the heart rate for aerobic exercise.

**Burning Fat**—To burn fat effectively, you must exercise at a low intensity level for a sustained period of time. During the first few minutes of exercise, your body uses carbohydrate calories for energy. Only after the first few minutes of exercise does your body begin to use stored fat calories for energy. If your goal is to burn fat, adjust the intensity of your exercise until your heart rate is near the lowest number in your training zone. For maximum fat burning, exercise with your heart rate near the middle number in your training zone.

**Aerobic Exercise**—If your goal is to strengthen your cardiovascular system, you must perform aerobic exercise, which is activity that requires large amounts of oxygen for prolonged periods of time. For aerobic exercise, adjust the intensity of your exercise until your heart rate is near the highest number in your training zone.

## WORKOUT GUIDELINES

**Warming Up**—Start with 5 to 10 minutes of stretching and light exercise. A warm-up increases your body temperature, heart rate, and circulation in preparation for exercise.

**Training Zone Exercise**—Exercise for 20 to 30 minutes with your heart rate in your training zone. (During the first few weeks of your exercise program, do not keep your heart rate in your training zone for longer than 20 minutes.) Breathe regularly and deeply as you exercise; never hold your breath.

**Cooling Down**—Finish with 5 to 10 minutes of stretching. Stretching increases the flexibility of your muscles and helps to prevent post-exercise problems.

## EXERCISE FREQUENCY

To maintain or improve your condition, complete three workouts each week, with at least one day of rest between workouts. After a few months of regular exercise, you may complete up to five workouts each week, if desired. Remember, the key to success is to make exercise a regular and enjoyable part of your everyday life.

## SUGGESTED STRETCHES

The correct form for several basic stretches is shown at the right. Move slowly as you stretch; never bounce.

### 1. Toe Touch Stretch

Stand with your knees bent slightly and slowly bend forward from your hips. Allow your back and shoulders to relax as you reach down toward your toes as far as possible. Hold for 15 counts, then relax. Repeat 3 times. Stretches: Hamstrings, back of knees and back.

### 2. Hamstring Stretch

Sit with one leg extended. Bring the sole of the opposite foot toward you and rest it against the inner thigh of your extended leg. Reach toward your toes as far as possible. Hold for 15 counts, then relax. Repeat 3 times for each leg. Stretches: Hamstrings, lower back and groin.

### 3. Calf/Achilles Stretch

With one leg in front of the other, reach forward and place your hands against a wall. Keep your back leg straight and your back foot flat on the floor. Bend your front leg, lean forward and move your hips toward the wall. Hold for 15 counts, then relax. Repeat 3 times for each leg. To cause further stretching of the achilles tendons, bend your back leg as well. Stretches: Calves, achilles tendons and ankles.

### 4. Quadriceps Stretch

With one hand against a wall for balance, reach back and grasp one foot with your other hand. Bring your heel as close to your buttocks as possible. Hold for 15 counts, then relax. Repeat 3 times for each leg. Stretches: Quadriceps and hip muscles.

### 5. Inner Thigh Stretch

Sit with the soles of your feet together and your knees outward. Pull your feet toward your groin area as far as possible. Hold for 15 counts, then relax. Repeat 3 times. Stretches: Quadriceps and hip muscles.

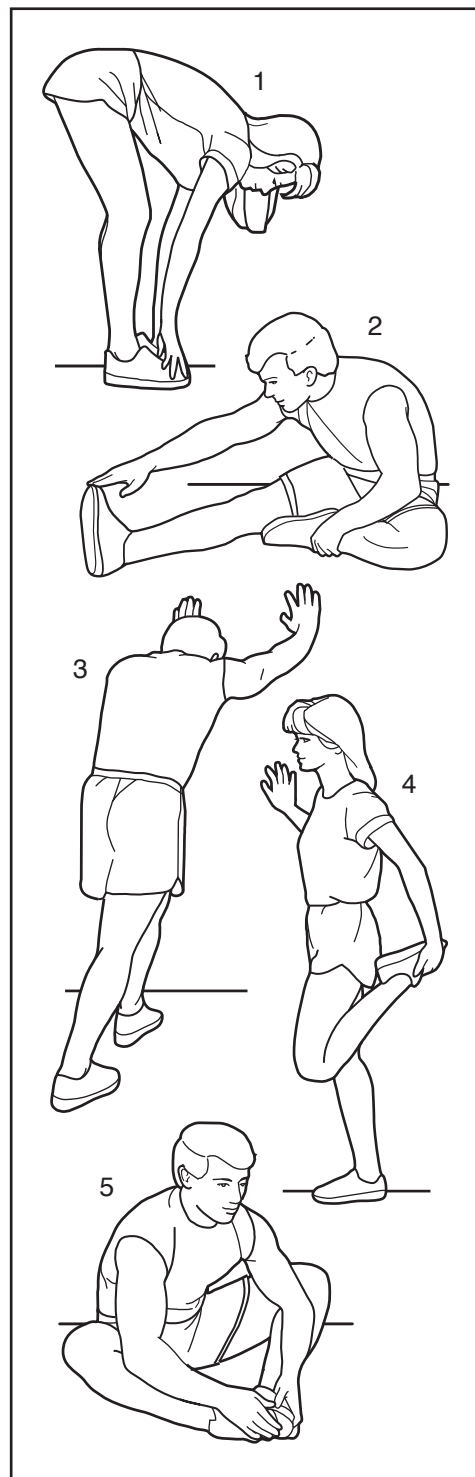

# PART LIST

Model No. NTEL18913.0 R1213A

Key No.	Qty.	Description	Key No.	Qty.	Description
1	1	Frame	51	4	Large Roller
2	1	Rear Stabilizer Cover	52	1	Left Lower Grip
3	1	Ramp	53	2	Axle Cover
4	1	Upright	54	1	Left Roller Arm Cover
5	2	Rear Stabilizer	55	2	Disc Cover
6	1	Right Front Stabilizer	56	1	Shield Cover
7	1	Console	57	4	Small Bushing
8	1	Front Stabilizer Cover	58	1	Right Pedal Arm
9	1	Left Front Stabilizer	59	1	Left Upper Saddle Bracket
10	1	Ramp Cover	60	1	Right Saddle Bracket Cover
11	2	Track	61	1	Right Upper Body Arm
12	1	Left Roller Arm	62	2	Foot
13	1	Lift Motor	63	2	Pulse Sensor
14	1	Left Pedal	64	4	M4 x 19mm Screw
15	1	Control Board	65	1	Ramp Axle
16	1	Power Switch	66	1	Left Outer Leg Cover
17	1	Power Cord Grommet	67	1	Left Inner Leg Cover
18	1	Crank	68	1	Upper Upright Cover
19	1	Pulley	69	1	Lower Upright Cover
20	2	Crank Arm	70	4	Upper Body Leg Bushing
21	4	Roller Arm Cap	71	2	Disc
22	1	Idler	72	4	Large Bushing
23	1	M17 Washer	73	1	Left Shield
24	2	Pulse Sensor Cover	74	1	Right Shield
25	1	Resistance Motor	75	1	Rear Shield
26	2	Lower Saddle Bracket	76	1	Frame Cover
27	2	Lift Frame Bushing	77	2	Upper Body Arm Cover
28	1	Eddy Mechanism	78	2	Key
29	1	Left Pedal Handle	79	2	M6 Acorn Nut
30	8	Medium Bushing	80	1	Accessory Tray Base
31	1	Lift Frame Axle	81	1	J-bolt
32	2	Pulse Sensor Cap	82	2	Pedal Spacer
33	2	Small Snap Ring	83	1	Small Crank Spacer
34	2	Wheel	84	1	Right Pedal Insert
35	2	Bolt Set	85	1	Left Pedal Insert
36	1	Right Upper Body Leg	86	2	Medium Roller
37	1	Accessory Tray	87	1	Right Pedal Plate
38	1	Reed Switch/Wire	88	1	Left Pedal Plate
39	1	Clamp	89	1	Upright Pivot Screw
40	2	Bearing	90	2	Frame Cap
41	1	Right Upper Grip	91	2	Ramp Cap
42	1	Medium Crank Spacer	92	4	Leveling Foot
43	2	Magnet	93	1	Large Snap Ring
44	1	Left Pedal Arm	94	2	Pedal Spring
45	1	Right Roller Arm	95	11	Post Fastener w/Screw
46	1	Left Upper Body Leg	96	4	Medium Snap Ring
47	1	Left Upper Body Arm	97	1	Roller Axle
48	1	Left Upper Grip	98	4	Clip Nut
49	1	Right Pedal	99	10	M10 Locknut
50	1	Right Lower Grip	100	1	Large Crank Spacer

Key No.	Qty.	Description	Key No.	Qty.	Description
101	1	Idler Screw	129	4	M10 Large Washer
102	7	M8 Locknut	130	4	M8 x 18mm Bolt
103	2	Pedal Pin	131	2	M8 Flat Head Screw
104	80	M4 x 16mm Screw	132	8	M10 x 20mm Screw
105	1	Lift Frame	133	4	M6 Washer
106	1	Small Roller	134	1	M10 x 48mm Bolt
107	4	Standoff	135	1	M10 x 36mm Bolt
108	1	Pulse Wire	136	4	M10 Washer
109	1	Transmitter	137	16	M4 x 10mm Screw
110	1	Main Wire Harness	138	10	M6 x 12mm Screw
111	1	Right Pedal Handle	139	4	M10 x 70mm Screw
112	1	Power Cord	140	2	M10 x 60mm Screw
113	1	Drive Belt	141	4	M4 Washer
114	1	Receiver Extension Wire	142	2	M10 x 75mm Screw
115	1	Chest Strap	143	4	M10 x 45mm Bolt
116	1	Receiver	144	12	M10 x 20mm Screw
117	4	M10 x 54mm Bolt	145	2	M8 Washer
118	2	M10 Nut	146	4	M4 x 12mm Flat Head Screw
119	2	M8 Washer	147	1	M8 Small Washer
120	2	M8 Shoulder Screw	148	4	M2.6 x 33mm Screw
121	1	Right Upper Saddle Bracket	149	6	M4 x 22mm Screw
122	1	Stop Plate	150	2	M12 Nut
123	1	Control Board Bracket	151	2	M12 I-bolt
124	4	M4 x 25mm Screw	152	4	Nylon Bushing
125	1	Right Inner Leg Cover	*	–	User's Manual
126	1	Right Outer Leg Cover	*	–	Assembly Tool
127	1	Bumper	*	–	Grease Packet
128	2	M8 Flat Washer	*	–	PTFE Grease Packet

Note: Specifications are subject to change without notice. For information about ordering replacement parts, see the back cover of this manual. \*These parts are not illustrated.

# EXPLODED DRAWING A

Model No. NTEL18913.0 R1213A

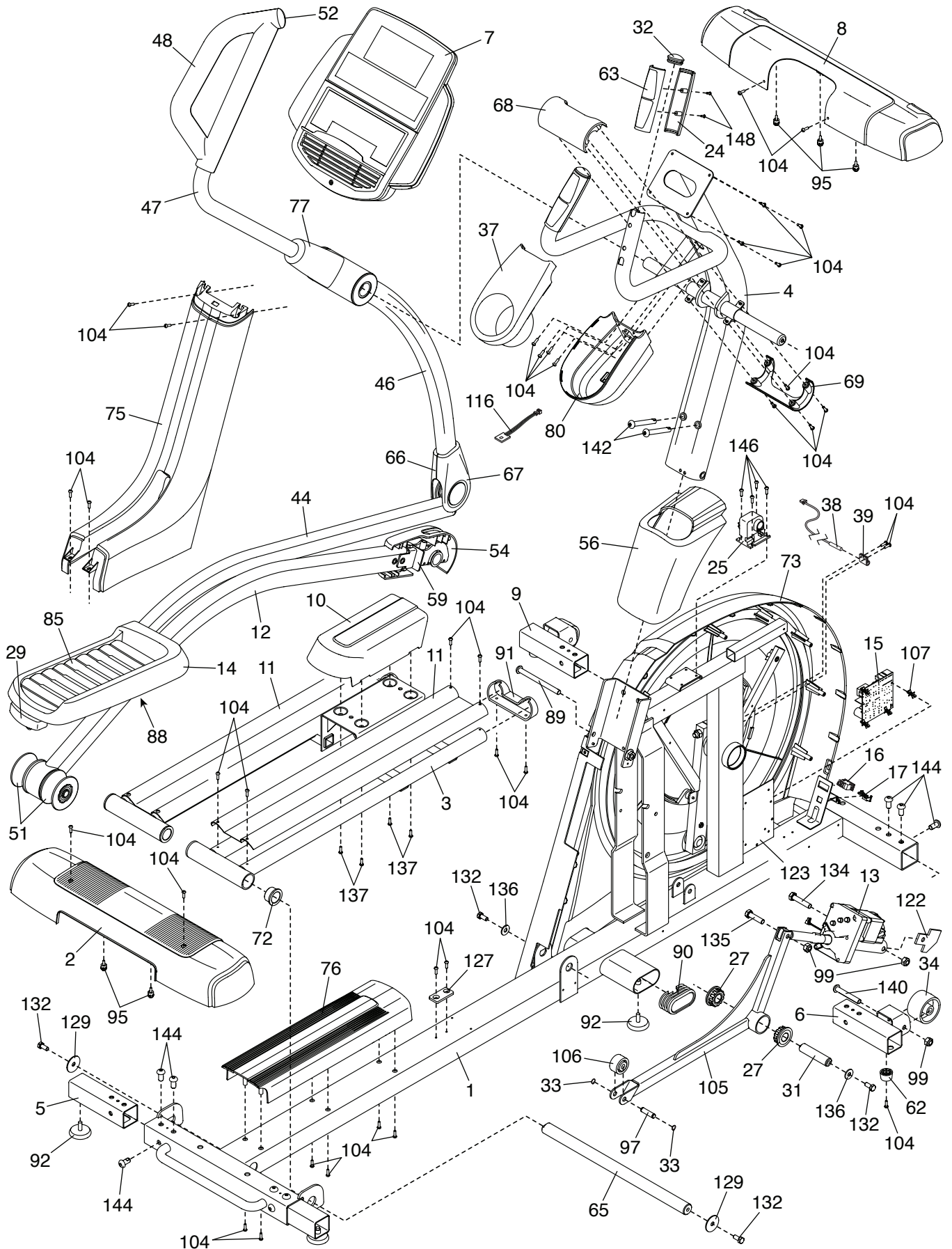

# EXPLODED DRAWING B

Model No. NTEL18913.0 R1213A

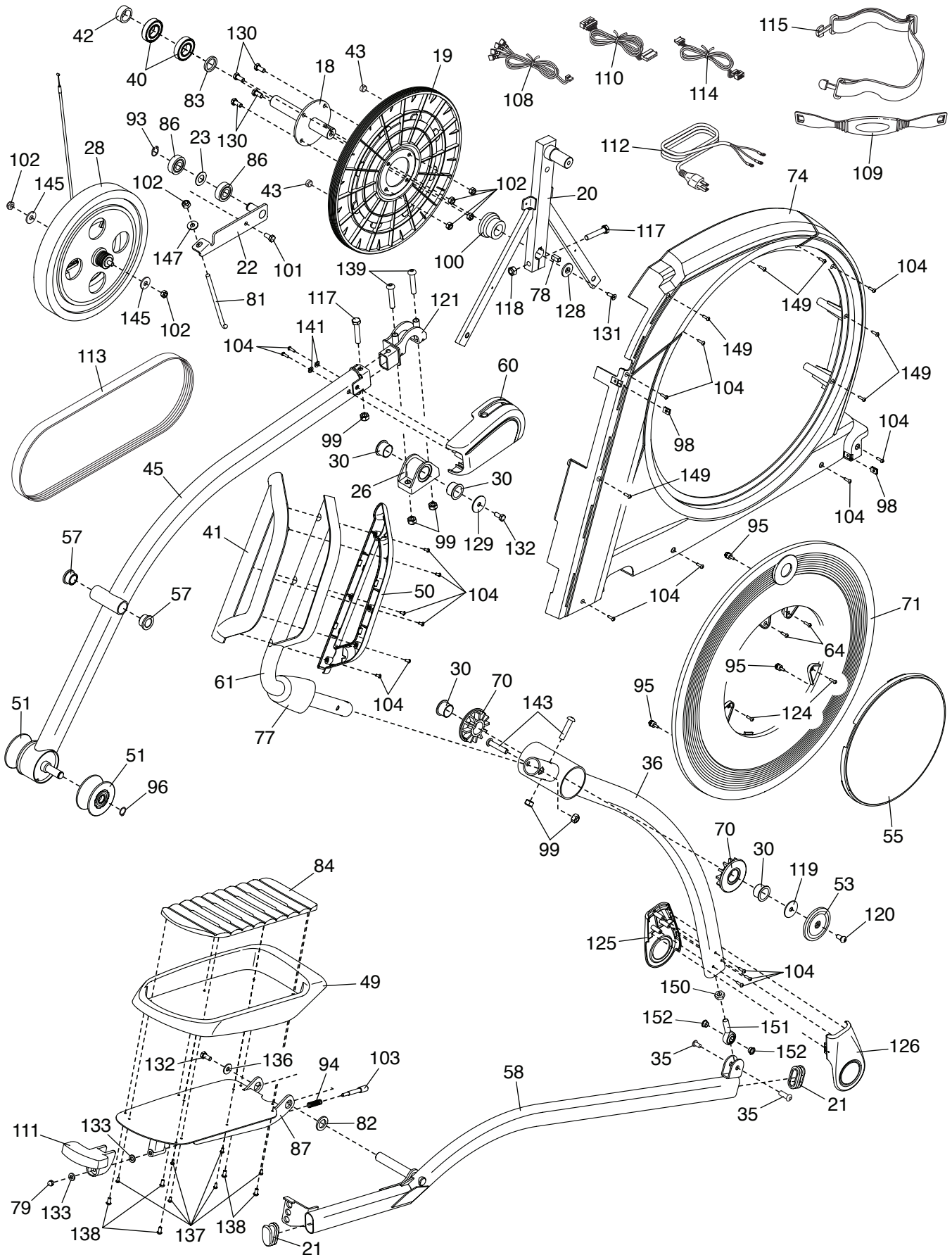

---

# ORDERING REPLACEMENT PARTS

To order replacement parts, please see the front cover of this manual. To help us assist you, be prepared to provide the following information when contacting us:

- the model number and serial number of the product (see the front cover of this manual)
- the name of the product (see the front cover of this manual)
- the key number and description of the replacement part(s) (see the PART LIST and the EXPLODED DRAWING near the end of this manual)

## LIMITED WARRANTY

**IMPORTANT: To protect your fitness equipment with an extended service plan, see page 5.**

ICON Health & Fitness, Inc. (ICON) warrants this product to be free from defects in workmanship and material, under normal use and service conditions. The frame is warranted for a lifetime. Parts are warranted for three (3) years from the date of purchase. Labor is warranted for one (1) year from the date of purchase.

This warranty extends only to the original purchaser (customer). ICON's obligation under this warranty is limited to repairing or replacing, at ICON's option, the product through one of its authorized service centers. All repairs for which warranty claims are made must be preauthorized by ICON. If the product is shipped to a service center, freight charges to and from the service center will be the customer's responsibility. If replacement parts are shipped while the product is under warranty, the customer will be responsible for a minimal handling charge. For in-home service, the customer will be responsible for a minimal trip charge. This warranty does not extend to freight damage to the product. This warranty will automatically be voided if the product is used as a store display model, if the product is purchased or transported outside the USA, if all instructions in this manual are not followed, if the product is abused or improperly or abnormally used, or if the product is used for commercial or rental purposes. No other warranty beyond that specifically set forth above is authorized by ICON.

ICON is not responsible or liable for indirect, special, or consequential damages arising out of or in connection with the use or performance of the product; damages with respect to any economic loss, loss of property, loss of revenues or profits, loss of enjoyment or use, or costs of removal or installation; or other consequential damages of any kind. Some states do not allow the exclusion or limitation of incidental or consequential damages. Accordingly, the above limitation may not apply to the customer.

The warranty extended hereunder is in lieu of any and all other warranties, and any implied warranties of merchantability or fitness for a particular purpose are limited in their scope and duration to the terms set forth herein. Some states do not allow limitations on how long an implied warranty lasts. Accordingly, the above limitation may not apply to the customer.

This warranty provides specific legal rights; the customer may have other rights that vary from state to state.

**ICON Health & Fitness, Inc., 1500 S. 1000 W., Logan, UT 84321-9813**